



A&N CORPORATION

custom fabrication and chambers





Custom Fabrication and Chambers

Custom Fabrication and Chambers Introduction 1.3

Manufacturing Capabilities	1.4 & 1.5
How to Specify a Chamber – Body Styles	1.6
How to Specify a Chamber – Coordinate Systems	1.7 – 1.9
How to Specify a Chamber – Port Specifications	1.10 & 1.11
How to Specify a Chamber – Additional Considerations	1.12 & 1.13
Custom Fabrication and Chamber Photo Gallery	1.14

A&N Corporation

707 Southwest 19th Avenue
Williston, Florida 32696
(352) 528-4100
1(800) FLANGE1
FAX (352) 528-3441
www.ancorp.com



Custom Fabrication AND CHAMBERS



Overview:

A&N has been building high and ultra high vacuum chambers for over 25 years. Vacuum chambers are employed in a variety of industries and applications. Our range of projects extends from one-of-a-kind chambers for research applications through production quantity chambers for OEM's. You will find A&N vacuum chambers in materials research labs (mass spectrometry, energy dispersive spectroscopy, Low Energy Electron Diffraction/Auger surface analysis), physics research labs (particle accelerators, condensed matter, nanotechnology), and chemical engineering labs (semiconductor processing). Our industrial customers are involved in coating (architectural glass, automotive parts, compact disks), helium leak detection, and semiconductor processing (Chemical Vapor Deposition, Physical Vapor Deposition, etching, ion implantation). A representative sampling of our work can be found in the photo gallery at the end of this section.

QUOTATIONS: Please contact our technical sales team when requiring a quotation. Quotations can be generated from simple, freehand sketches. Electronic files should be sent in DWG, DXF, or IGES file formats. When needed, A&N can supply a complete set of engineered drawings. For assistance with specifications and design communication, please see the section, "How to Specify a Vacuum Chamber" on pages 1.6 - 1.13.



Overview of our capabilities:

High and ultra high vacuum chambers are engineered products that require a specialized set of materials and fabrication processes. To help designers and practitioners better understand system specifications, a brief overview of A&N's capabilities and practices follows:

Materials

Standard materials: Because of its high corrosion resistance, low outgassing rates, wide range of applicable temperatures, machinability, weldability, and relative cost, A&N's standard material for tube sections, spheres and roll-ups is 304L stainless steel. Many other materials are available upon request. A&N routinely works with 304, 316, and 316L stainless steels as well as 6061 T6 aluminum; 360 free machining brass can also be supplied.

A&N specifies a magnetic permeability not to exceed 1.02μ when ordering raw 304 stainless materials. Welding and machining processes may result in heat affected or cold-worked zones that may increase magnetic permeability in these zones. Minimizing seams, joints, and bends in areas of high magnetic sensitivity should be considered during the design process. For applications that require superior magnetic flux shielding, mu-metal can also be supplied.

Flanges: A&N's flanges are made from specially manufactured raw stock that is designed to maximize the vacuum capabilities of 304 stainless. These processes minimize impurities and inclusions that could adversely impact the steel's ability to maintain vacuum. Grain size, orientation, and density are also engineered to maximize the vacuum performance of the raw stock.

Fabrication

Welding

A&N uses tungsten inert gas (TIG/GTAW) welding techniques with high purity argon as the backfill/purge gas. Both manual and automated orbital welding machines are employed. In accordance with good UHV fabrication practices, non-filler material, internal fusion weld joints are utilized wherever possible. In those instances where geometries preclude internal welds, one hundred percent, full penetration welds are provided. To minimize sources of virtual leaks, external welds are only used when required for structural reinforcement and are limited to stitch, skip, span, or spot weld configurations.

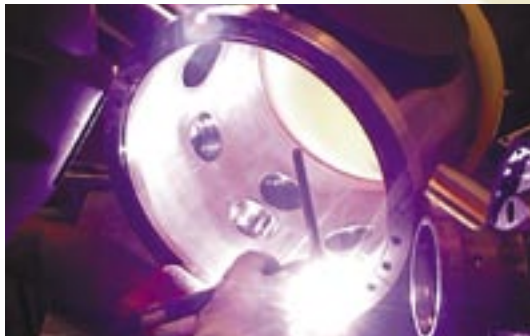

Machining

State-of-the-art, multi-axis, CNC machine centers are at the heart of A&N's operations. Our work processes are built upon the dual goals of high quality and rapid turnaround. Our machining coolants are sulphur free, biodegradable, and recycled.

Surface Finishes

Flanges and machined components (faced, turned or bored) come standard with a 32 micro-inch surface finish. Chambers are internally and externally bead blasted. Electropolishing and manual polishing are additional options.



A&N Corporation

707 Southwest 19th Avenue
Williston, Florida 32696
(352) 528-4100
1(800) FLANGE1
FAX (352) 528-3441
www.ancorp.com



Cleaning and Packaging

Upon final machining, all components are washed in a heated ultrasonic detergent bath followed by multiple ultrasonic deionized water rinses to remove all residual machining lubricants. After final rinse, parts are blown dry with dry, heated, filtered air and packaged.

After cleaning and testing, flanges and small components are hermetically sealed in vacuum board packaging and are ready for UHV installation. Larger flanges are covered with a layer of foil and protective plastic shields. Weldments and assemblies are then bagged, bubble-wrapped, and inserted into a shipping container surrounded by void filling “pillow” wrap. Custom crating is available.



Leak Testing and Quality Control

All weld joints and sealing surfaces are certified with state-of-the-art helium mass spectrometer leak detectors to a maximum rate of 1×10^{-9} std. cc helium. Leak testing is typically conducted in an “outside-in” or tracer-probe configuration. Helium (gas) bag tests are conducted as needed.

The highest standards of quality control inform every aspect of our operational practices. We welcome customer audits. Dimensional checks are confirmed with a computer controlled coordinate measuring machine (CMM). Material and CMM certifications can be provided upon request.

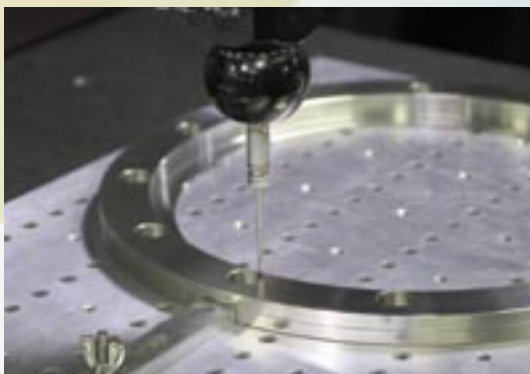



How to specify a custom chamber

There are three basic steps to specifying a custom vacuum chamber:

- 1) Specify the main body style and dimensions;
- 2) Specify chamber ports (2a) and port mounting configurations (2b); and
- 3) Specify application specific design considerations.

Spherical

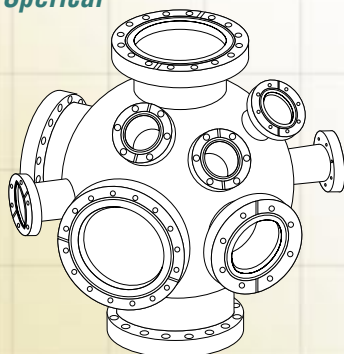

Figure 1

Cylinder

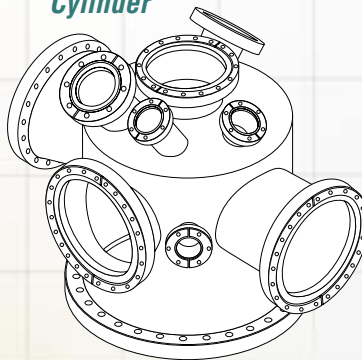

Figure 2

Box

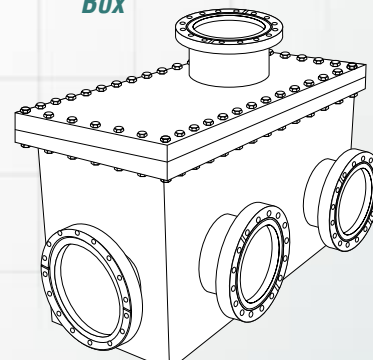

Figure 3

STEP 1

There are essentially three main body styles that are commonly used in vacuum applications today:

1. **Spheres and hemispheres:** Two hemispheres are welded together to form a spherical chamber body. A spherical configuration provides the highest surface area to volume ratio and is (often) lighter than a cylindrical chamber of similar volume. However, manufacturing considerations often make spherical chambers the least economical solution.
2. **Cylinders with hemispherical ends, flat ends, or flanged ends:** The body of these chambers is made of either vacuum grade tubing or a custom tubing “roll-up” depending on the diameter required. The lid and baseplate are made from a dish head, hemisphere or customized blank flange. Cylindrical chambers are the most commonly chosen vacuum chamber configuration.
3. **Rectangular or cubic boxes:** These chambers are manufactured with metal plate material that is custom machined and welded to form the chamber body.

Once a main body style is chosen, specify the appropriate overall outer dimension(s).

Figures 1 through 3 show examples of each main body style.

A&N Corporation

707 Southwest 19th Avenue
 Williston, Florida 32696
 (352) 528-4100
 1(800) FLANGE1
 FAX (352) 528-3441
 www.ancorp.com



STEP 2a:

Choose the appropriate three-dimensional coordinate system (spherical, modified cylindrical, or cartesian) and specify each port center in coordinates of the chosen system. A complete specification of a port center includes:

1) The center point of the port in the appropriate coordinate system, 2) The focal length, 3) The focal point.

Examples of how these coordinate systems are applied to each of the typical main body styles are provided in Figures 4 through 6. A complete port specification example for a cylindrical chamber is provided in Figure 7 and in the table on p. 1.10.

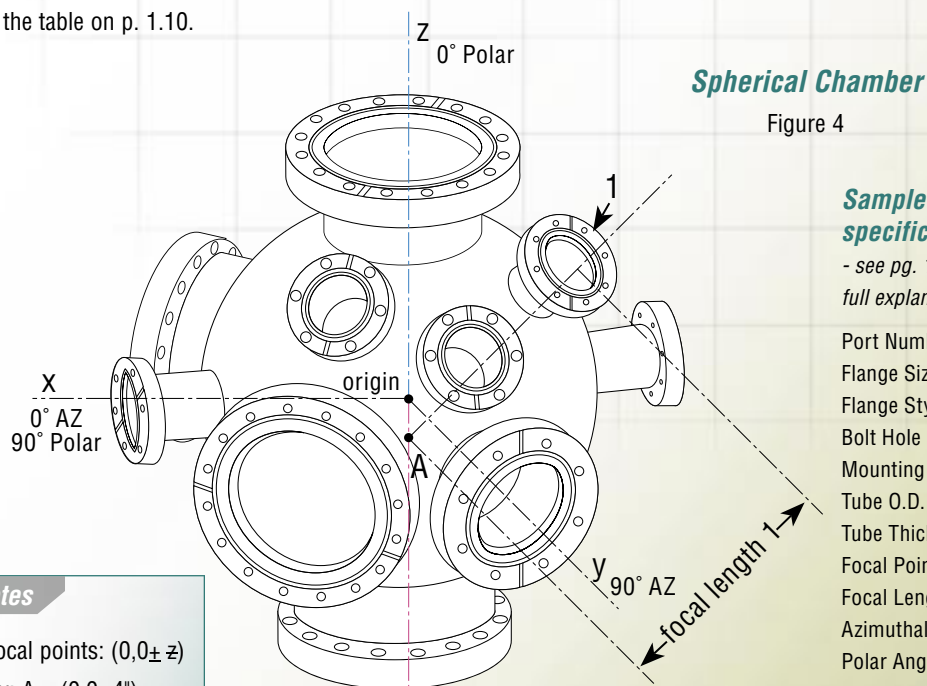

Spherical Chamber

Figure 4

Sample port specification data

- see pg. 1.10 for a full explanation

- Port Number: **1**
- Flange Size (1): **CF275**
- Flange Style (2): **R**
- Bolt Hole Style (3): **H**
- Mounting Config. (4): **T**
- Tube O.D. (in): **1.50**
- Tube Thickness (5): **Standard**
- Focal Point: **A**
- Focal Length (in): **16.00**
- Azimuthal Angle: **135°**
- Polar Angle: **60°**

Notes

focal points: $(0, 0, \pm z)$
 ex: A = $(0, 0, -4)$
 focal length 1 = 16"

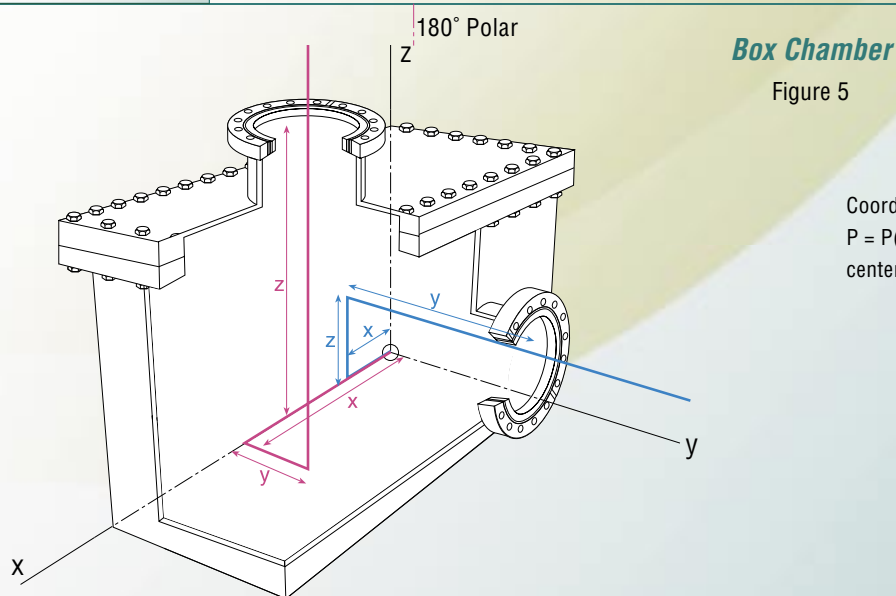

Box Chamber

Figure 5

Coordinates of the point $P = P(x, y, z)$ specify the center of the flange.



STEP 2a:

Choose the appropriate three-dimensional coordinate system (spherical, modified cylindrical, or cartesian) and specify each port center in coordinates of the chosen system. A complete specification of a port center includes:
 1) The center point of the port in the appropriate coordinate system, 2) The focal length, 3) The focal point.
 Examples of how these coordinate systems are applied to each of the typical main body styles are provided in Figures 4 through 6. A complete port specification example for a cylindrical chamber is provided in Figure 7 and in the table on p. 1.10.

Cylindrical Chamber
Figure 6A

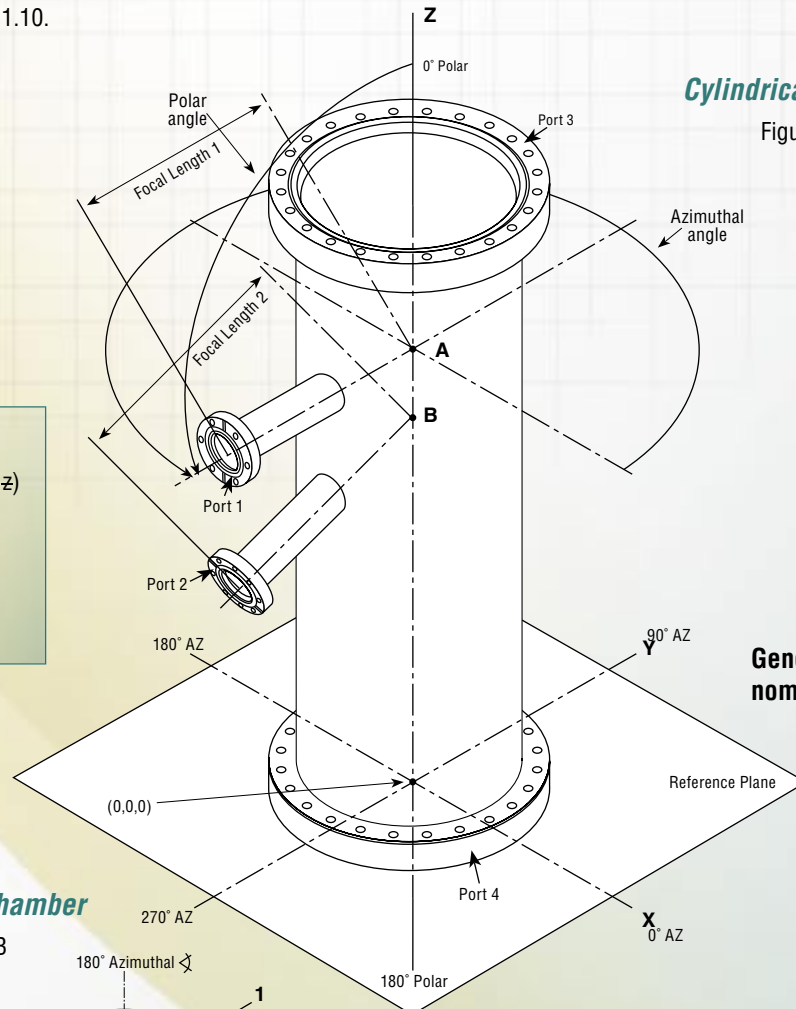

Notes
 focal points: $(0,0,z)$
 $(x=0, y=0,z)$
 examples:
 $A = (0,0,24^\circ)$
 $B = (0,0,20^\circ)$

General chamber nomenclature

Cylindrical Chamber
Figure 6B

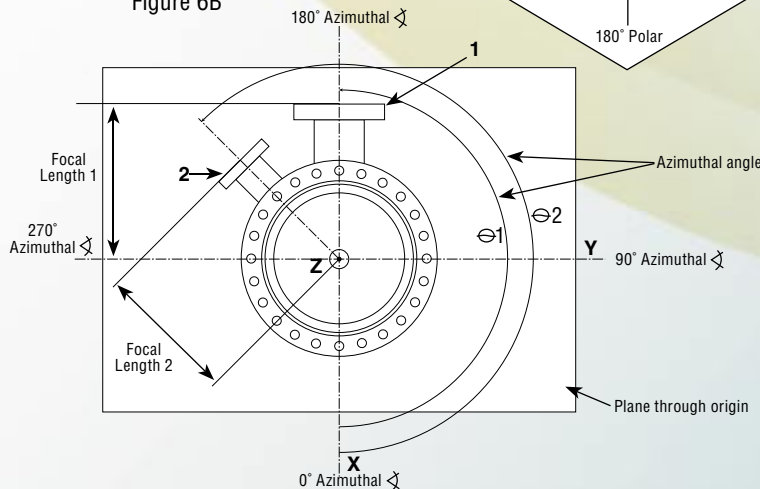

A&N Corporation
 707 Southwest 19th Avenue
 Williston, Florida 32696
 (352) 528-4100
 1(800) FLANGE1
 FAX (352) 528-3441
 www.ancorp.com



STEP 2a:

Using the conventions provided in this section, steps 2a and 2b have been completed for the seven ports shown on the cylindrical chamber below (Figure 7). The data have been summarized in the table on p. 1.10.

Notes

focal points: (0,0,z)

examples: "A" 0,0,0

"B" 0,0,10

"C" 0,0,8

Cylindrical Chamber

Figure 7

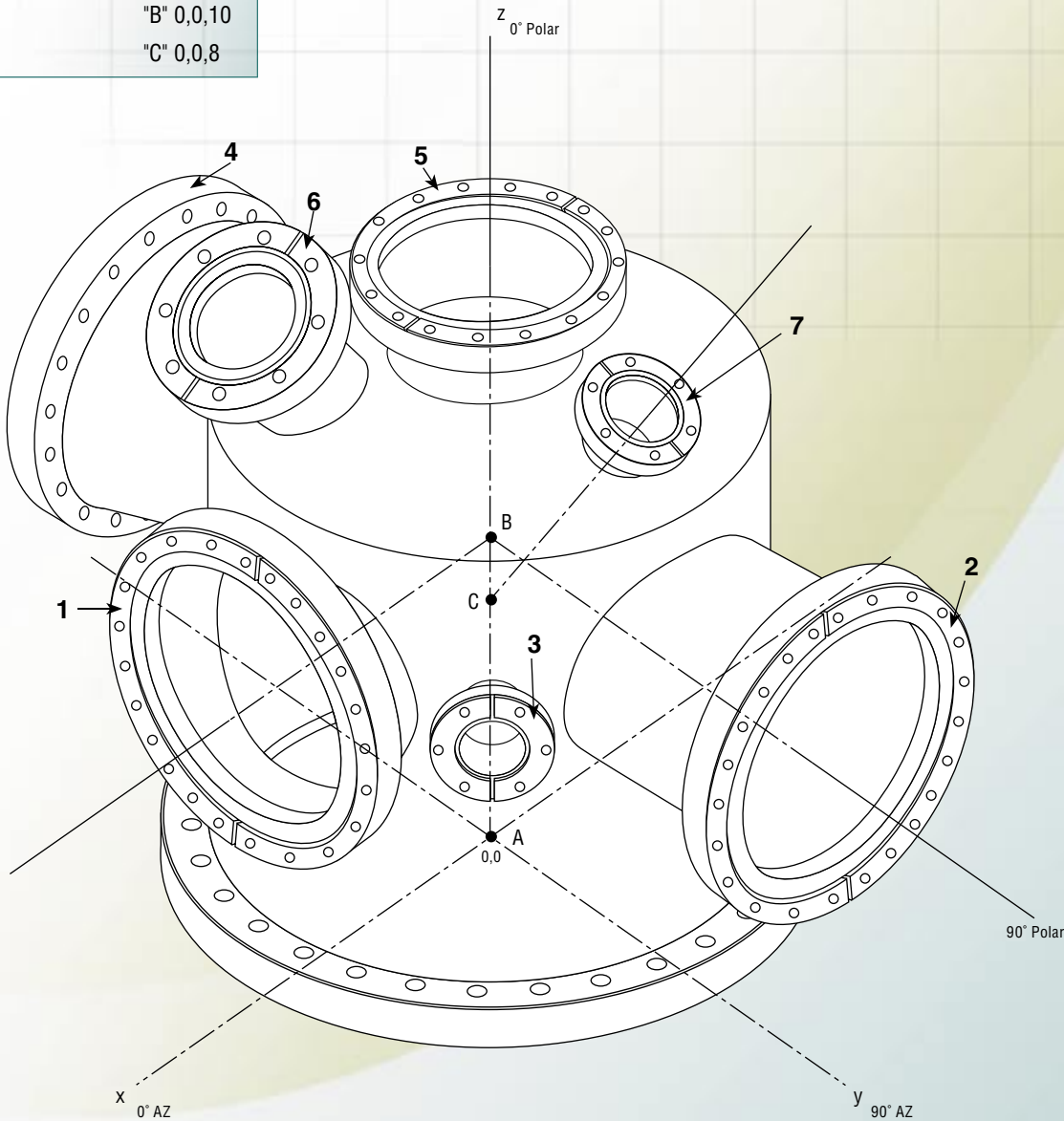

**Port labels 1-7 are references for the port specification table.
This is step 2b. See ppg. 1.10 & 1.11**

**STEP 2b**

Once the port center coordinates are determined, fill out the following port matrix to complete the port specifications:

PORT NUMBER	FLANGE SIZE ¹	FLANGE STYLE ²	BOLT HOLE STYLE ³	MOUNTING CONFIG. ⁴	Table A		Step 2a			
					TUBE O.D. (IN)	TUBE THICKNESS ⁵	FOCAL POINT	FOCAL LENGTH(IN)	AZIMUTHAL ANGLE	POLAR ANGLE
1	CF800	R	H	T	6.00	Standard	B	9.00	0°	90°
2	CF800	R	H	T	6.00	Standard	B	12.00	90°	90°
3	CF275	F	H	T	1.50	Standard	B	8.00	45°	90°
4	CF800	F	H	T	6.00	Standard	B	12.00	270°	90°
5	CF600	R	H	T	4.00	Standard	A	22.00	N/A	0°
6	CF450	R	H	T	2.50	Standard	B	12.00	330°	30°
7	CF275	R	H	T	1.50	Standard	C	12.00	90°	45°

1 - Flange Size: Please refer to the catalog for all possible flange sizes.

Representative examples are provided here:

Small ISO: QF 25, QF40, etc.

Large, Clamp or Bolted ISO: LF80, LFB100, etc.

Conflat: CF275, CF1200, etc.

2 - Flange Style (applicable to CF and ASA only):

R –Rotatable

F –Fixed

3 - Bolt Hole Style (applicable to CF and ASA only):

T –Tapped

H –Through hole

4 - Mounting Configuration:

F –Flush Mount

ZF –Zero Length Fixed

ZR –Zero Length Rotatable

T –Tubulated

M –Machined

Examples of the each of the mounting configurations are provided on the facing page.



5 - Tube Thickness: Specify if known or state “Standard” if A&N should select tube thicknesses.

Table B provides some guidelines on tube thicknesses.

Table B

TUBE O.D. (INCHES)	TYPICAL TUBE WALL THICKNESS (INCHES)
0.25	0.039
0.38	0.049
0.5 to 3.0	0.065
4.0 to 6.0	0.083
6.0 to 12.75	0.120

A&N Corporation

707 Southwest 19th Avenue
Williston, Florida 32696
(352) 528-4100
1(800) FLANGE1
FAX (352) 528-3441
www.ancorp.com



Port Mounting Configurations

(reference pg. 1.10, step 2b, note 4)

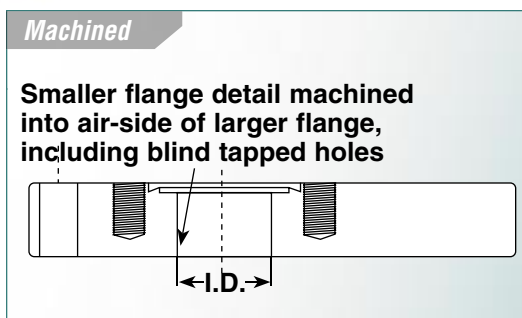
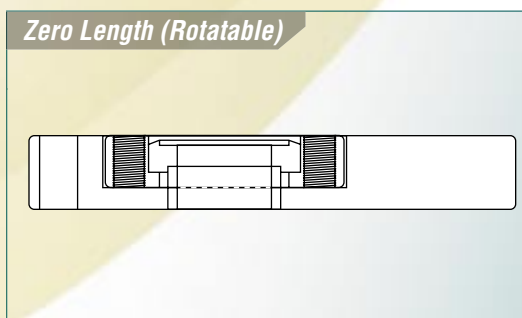
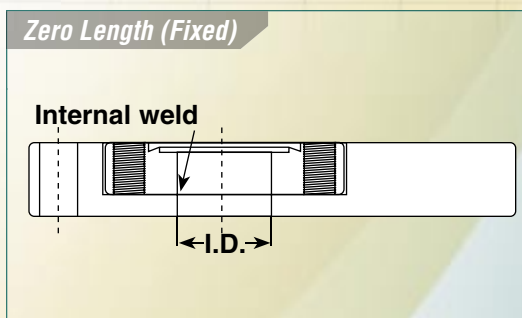
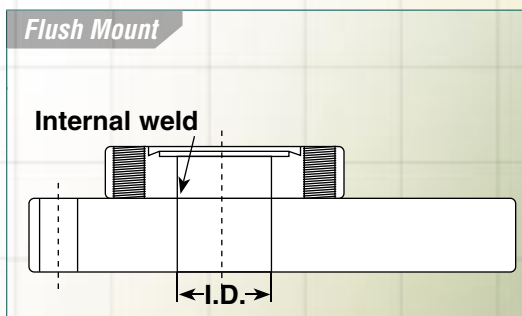
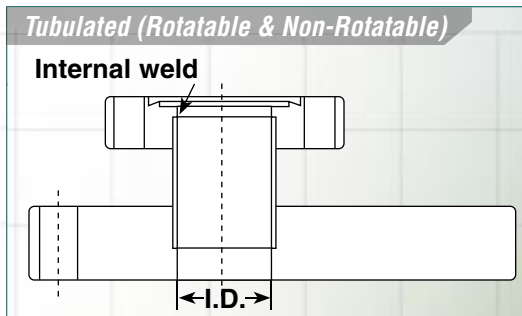
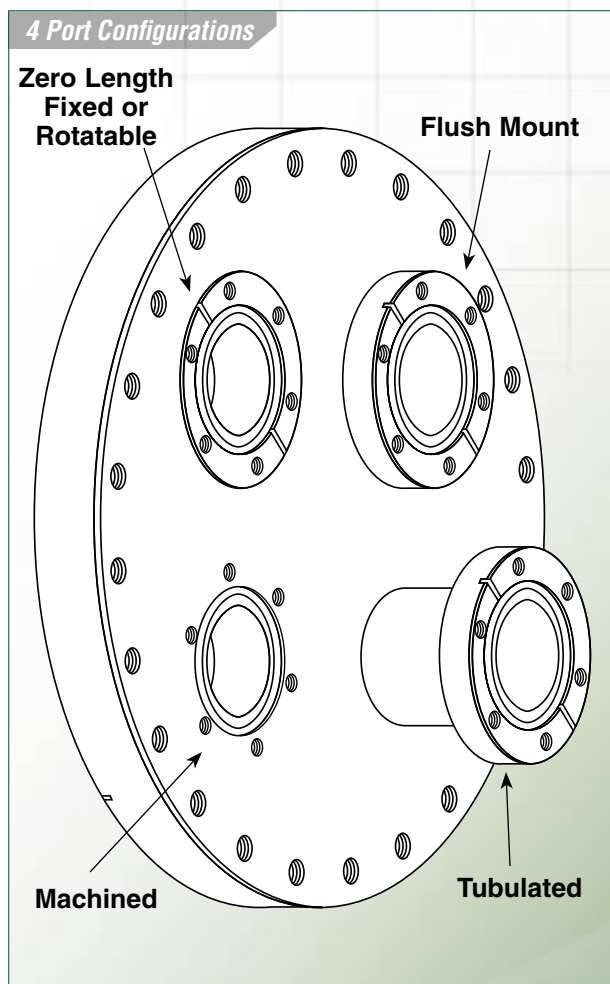



STEP 3

Specify application specific design considerations. A minimum set of criteria are provided here:

- a. **Material:** Specify if other than 304L stainless steel.
- b. **Main body wall thickness:** Specify if known or state "Standard" if A&N should select the thickness.
- c. **Bolt hole orientation:** Specify, as shown in Figure 7 below, if known or state "Standard" if A&N should select the bolt hole orientation (for non-rotatable flanges). The orientation of leak check grooves on CF flanges should be indicated if critical.

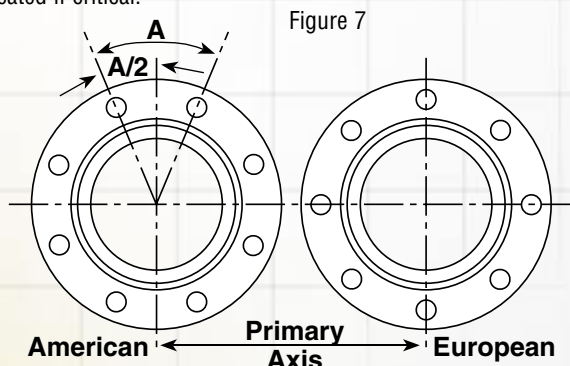

- d. **Clamp and bolt kit clearances:** Be sure that tubulated flange mounts have the minimum clearances as shown in Table C & D below:

Table C - ISO Clamp Clearance

FLANGE SIZE	MIN. DIA. TO INSTALL A	MAX. DIA. CLOSED B	MIN. DIA. CLOSED C
QF-10	2.86	2.65	1.75
QF-16	2.86	2.65	1.75
QF-25	3.32	3.00	2.24
QF-40	4.00	3.72	2.90
QF-50	5.45	4.62	3.69

Table D - CF and ASA/ANSI Clearance

FLANGE TYPE	FLANGE SIZES	RECOMMENDED MINIMUM CLEARANCE TO BACK OF FLANGE
CF	All	1/2"
ASA/ANSI	100 to 400	1"
ASA/ANSI	600 to 1000	1 1/2"

If your design cannot accommodate these distances A&N recommends tapped bolt holes for your flanges.

- e. **Tolerances:** Specify if known or state "Standard" if A&N standard tolerances should be applied. A&N's standard tolerances are provided in Table E (to the right):

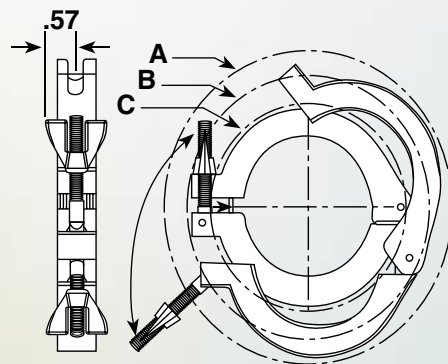

Table E

STANDARD TOLERANCES	
Machined Dimensions:	
.XXX	+/- 0.005"
.XX	+/- 0.010"
.X	+/- 0.025"
Fraction	+/- 1/16"
Welded Dimensions:	
<= 24"	+/- 0.030"
> 24"	+/- 0.060"
Angle (port alignments):	
	+/- 0.5 degrees

A&N Corporation

707 Southwest 19th Avenue
 Williston, Florida 32696
 (352) 528-4100
 1(800) FLANGE1
 FAX (352) 528-3441
 www.ancorp.com



f. Water-cooled jacketing: A&N manufactures two styles of water-cooled chambers for high temperature or high heat flux applications:

1. **Double-Wall Construction:** Double-wall construction is most often used in those applications requiring uniform internal chamber temperatures. Typically, double-wall, water-cooled chambers are made with internal baffles that help provide uniform, laminar water circulation.

2. **Channel Construction:** Channel construction is most often used in those applications requiring localized or targeted cooling. Because it involves a fair amount of hand fitting work to install, channel construction is often more expensive than double-wall construction.

Double Wall Construction

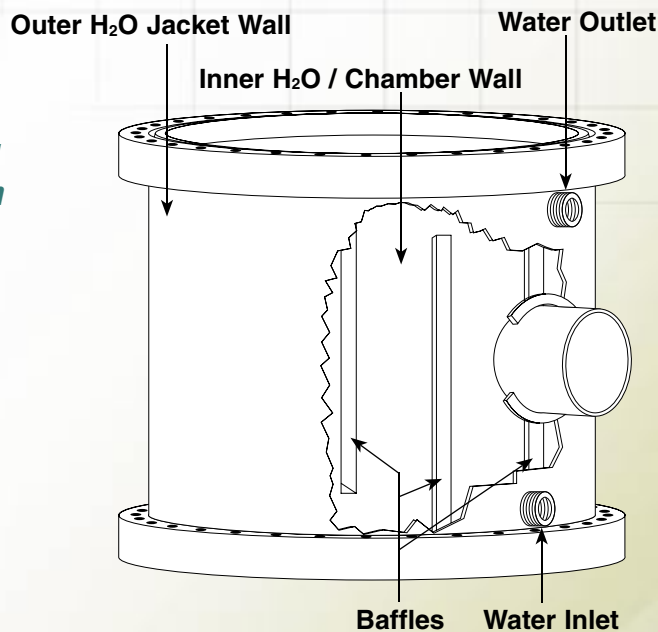

Channel Construction

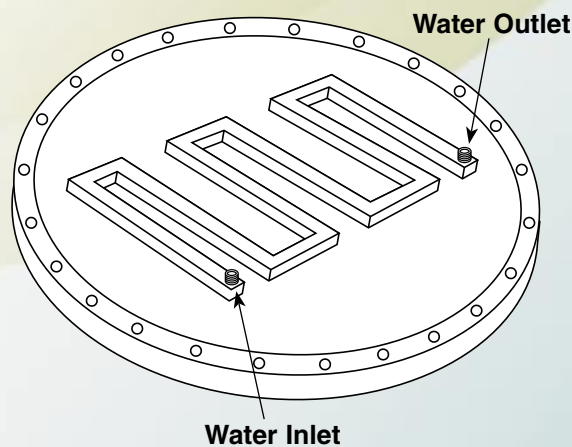

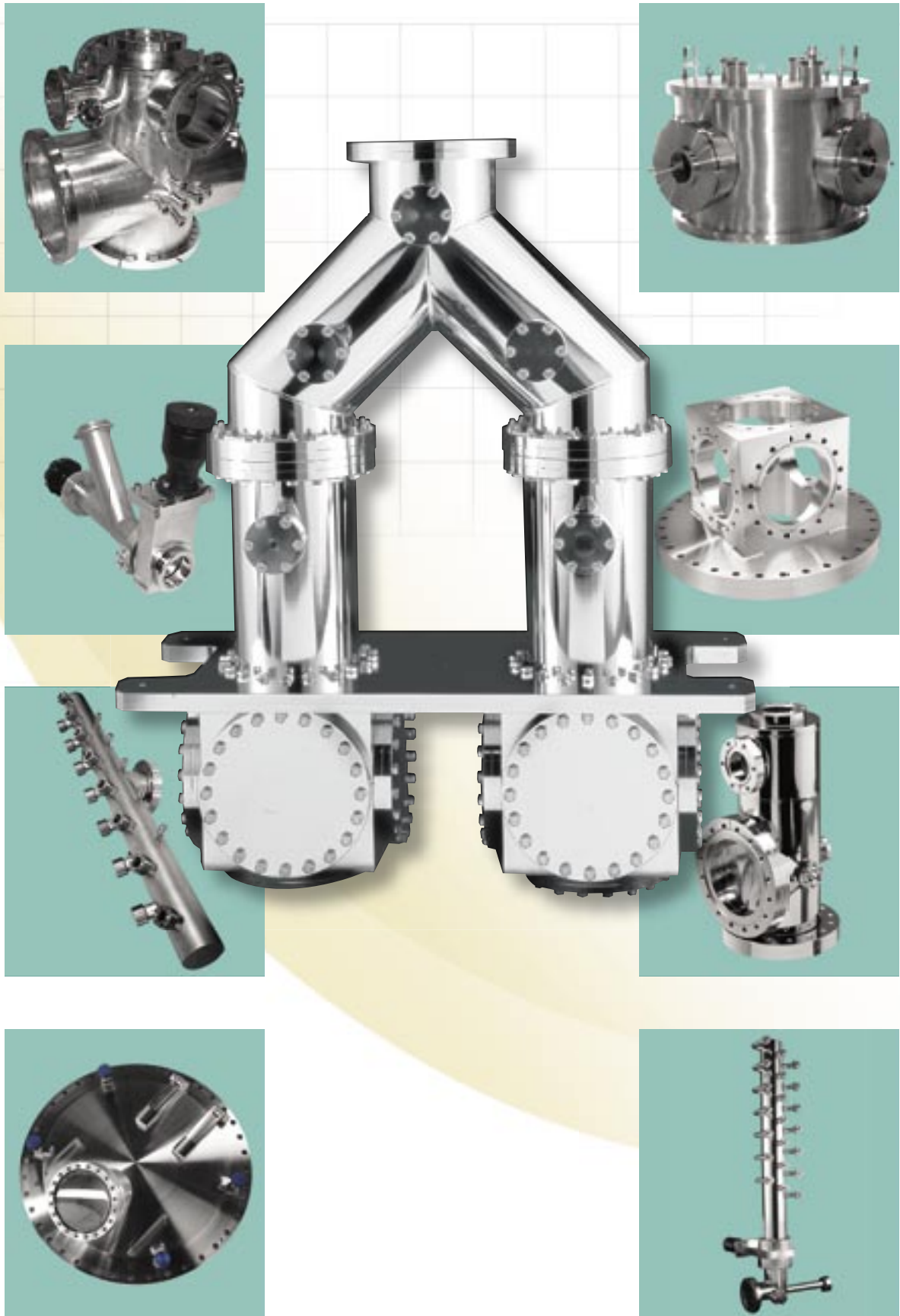

A&N Corporation

707 Southwest 19th Avenue
Williston, Florida 32696
(352) 528-4100
1(800) FLANGE1
FAX (352) 528-3441
www.ancorp.com